

ProductionLine
TESTERS

IC100-A



OPT (Optics Module)

Features:

- 6 Visible Light LED's in 3 groups for various intensities
- Programmable current sources set light level
- Infrared LED for Proximity Sensor testing
- IR-LED has variable current pulsing synchronously with DUT
- Infrared photodiode with Current-to-Voltage converter

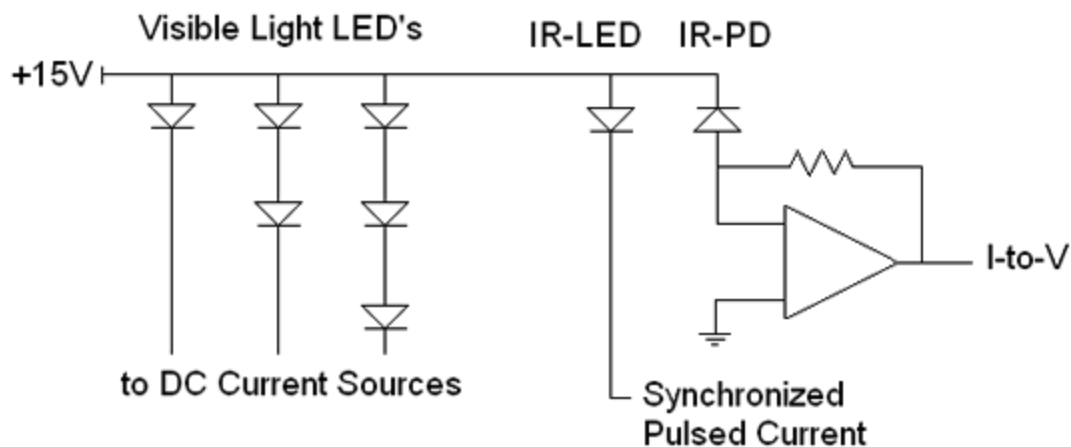

Specifications:

- Programmable from <1 Lux to >1000 Lux (250Klux optional)
- I-to-V Converter Gain = 1000, i.e. 1 μ A = 1mV
- Synchronous IR-LED simulates various distances